



tempering valve art 5218



art 5218 tempering valve



Application

A tempering valve is used in systems where the water in the storage cylinder can reach temperatures significantly above 60°C for example if heated by solar heating.

They are used with multiple outlets and frequently as part of a re-circulating domestic hot water system.

In the event of failure of the hot or cold water supplies the Art 5218 will automatically shut off, stopping water discharging from the mixed water outlet.

BS EN 15092 and DTC Scheme

BS EN 15092 "In line hot water supply tempering valves. Tests and requirements" specifies the performance characteristics of tempering valves installed at the point of distribution in domestic hot water systems.

Art 5218 tempering valves are certified by Buildcert and the DTC Scheme as meeting these requirements.

	Limits of use	Recommended limits for operation
Dynamic pressure	0.2 bar min	1 bar ≤ P ≤ 5 bar
Static pressure	10 bar max	
Hot water inlet temperature	T ≤ 90°C	60°C ≤ T ≤ 80°C
Cold water inlet temperature	T ≤ 25°C	T ≤ 25°C
Distribution (outlet) temperature	55°C ≤ T ≤ 60°C (DTC Scheme)	
Distribution (outlet) temperature	45°C ≤ T ≤ 65°C (BS EN 15092)	

Note: Valves operating outside these conditions cannot be guaranteed by the scheme to operate as DTC approved valves.

Application Diagram

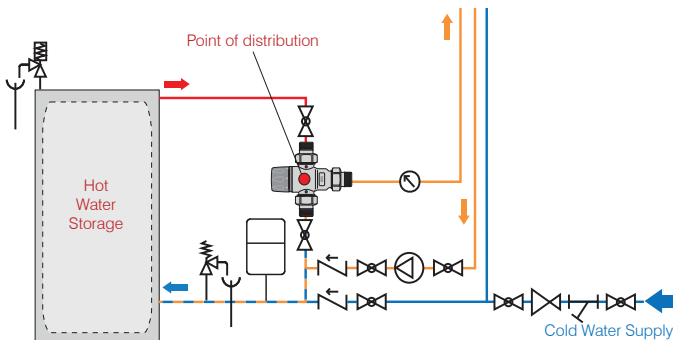

E & O.E

Dimensions

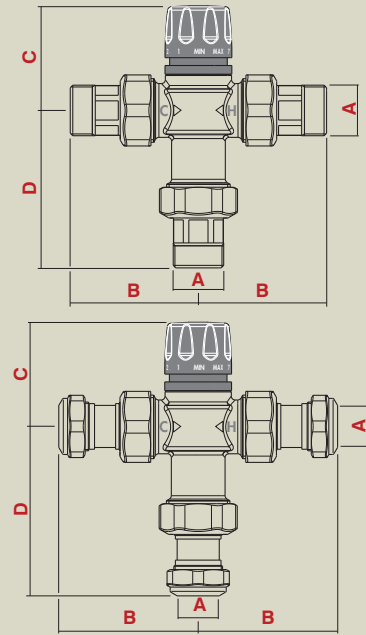

Prod Code	A	B	C	D	Wt. kg
521814	R ¹ / ₂	62.5	54	82	0.64
521815	R ³ / ₄	67	55	82	0.81
521816	R1	83.5	72	100	1.20
521817	Ø15	67.5	54	87	0.70
521818	Ø22	75.5	55	90.5	0.91
521819	Ø28	99.5	72	117	1.40

Technical Data

Max. working pressure:	10 bar - Static 5 bar - Dynamic
Max. inlet temperature:	90°C
Max. inlet pressure ratio H/C or C/H:	2:1
Min. temperature difference between hot water inlet and mixed water outlet for best performance:	10°C
Temperature setting range:	45 to 65°C
BS EN15092 set temperature range:	45 to 65°C
*Set water temperature:	55 to 60°C
Accuracy:	±2°C
Min. flow rate for stable operation:	
½", 15, ¾" & 22 sizes	4 l/m
1" & 28 sizes	6 l/m

*In the UK to comply with the requirements of the UK Water Supply (Water Fitting) Regulations 1999 G18.3 and with Part G of the Building regulations clause 3.63 tempering valves must be set to operate at a mixed water outlet temperature of between 55 and 60°C.

Certified to standard: BS EN 15092 and DTC scheme.

Designation: Type 2 - adjustable

Construction Details

Component	Material	Grade
Body	DZR Brass	BS EN 12165 CW602N chrome plated
Shutter	PSU	
Spring	Stainless steel	
Seals	EPDM	
Cover	ABS	



Mustang Drive, Stafford, Staffordshire. ST16 1GW
t • 01785 218200 f • 01785 218201 e • sales@altecnic.co.uk www.altecnic.co.uk

CarbonNeutral®company