

Scheme 1

Operate on the check valve above the pump with a screwdriver (see **Shut-off and check valve** paragraph).

Open the discharge valves positioned on the upper part of the system.

### Shut off and check valve

The handles with integrated manometers action the shut-off ball valve; the same valve integrates the check valve.

To allow the fluid pass through on both directions on the check valve (blue handle), you need to operate on the little screwdriver-stem on the valve's body (follow scheme 1). The stem allows the check valve to open.

During the normal working of the system, the shut-off ball valves have to be completely opened, so the handles have to be completely turned anticlockwise and the check valve has to be in the **CLOSED** position.

### Flowmeter

The flowmeter is made of a flow measure-device and of a flow regulation valve. To correctly work, the flowmeter has to be vertically positioned.

In the same valve, two shut-off valves are integrated to fill-in and flush the system. The flow regulation is allowed by operating with the screwdriver-stem, as per scheme 2.

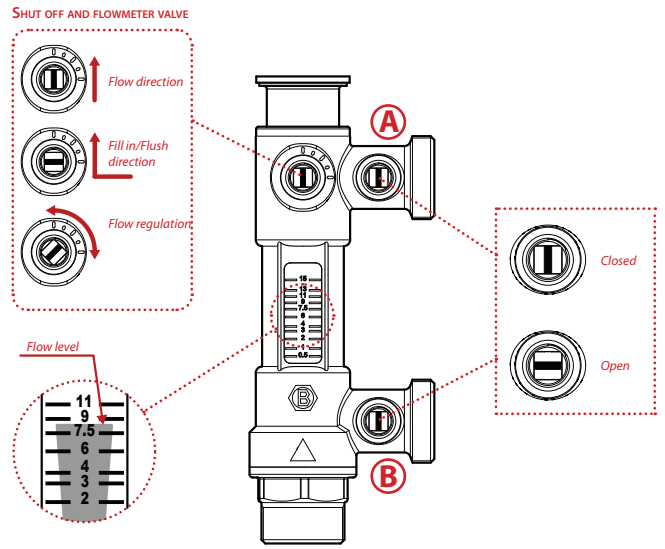

Scheme 2

### De-aerator

The de-aerator is a device aiming at separate air with a divider-device on the supply. Gas divided from fluids are collected in the higher part of the de-aerator and can be flushed through a partial opening of the air vent.

We suggest to use a key to avoid any bursting, as per scheme 3.

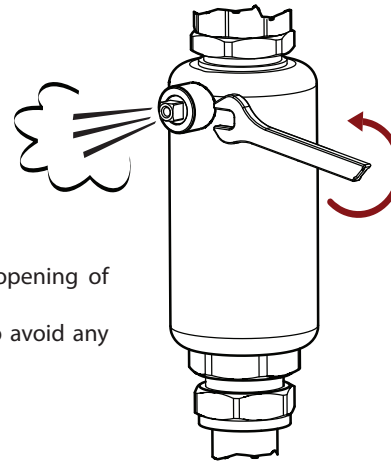

Scheme 3

# Assembling Istructions

## Application

The pump station is installed on the primary system of the forced circulation solar system. The station begins to work when a signal comes from the hot water cylinder indicating that the temperature has undergone a prefixed minimum level. The station is equipped with safety devices for the correct working of the system.

## Characteristics

Body & Components	UNI EN 12165 CW617N Brass
Washer & tightness Orings	Viton / Klinger
Insulation Box	EPP
Thermic Insulation ( $\lambda$ 10 °C)	0,038 W/mK
Fluids	Water & Glycol Solution (50% max)
Max working pressure	10 bar
Flow rate regulator max working temperature	140 °C
Shut-off and check valves max working temperature	140 °C
De-aereter max working temperature	140 °C
Safety valve max working temperature	160 °C
Safety valve calibration	6 bar (3 bar on request)
Connections (G)	3/4" F • 3/4" M • mm18 • mm22
Expansion Vessel connection	3/4" M
Fill & Discharge connection	3/4" M & hose connection
<b>Grundfos</b> circulation pump	<b>Solar 15-65 130 / Solar 15-70 130</b>
Body material	Cast Iron
Power supply	230V - 50 Hz
Max pressure	10 bar
Max temperature	110 °C

## Dimensions

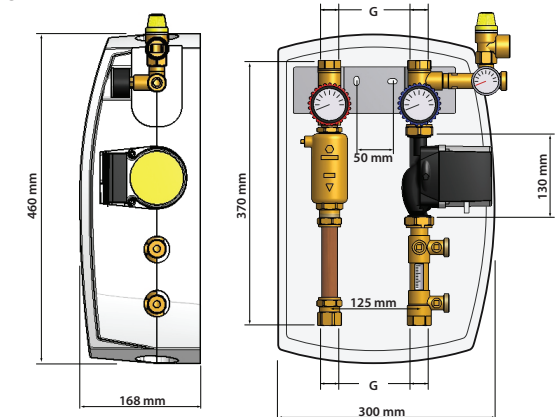

## Station Installation's template

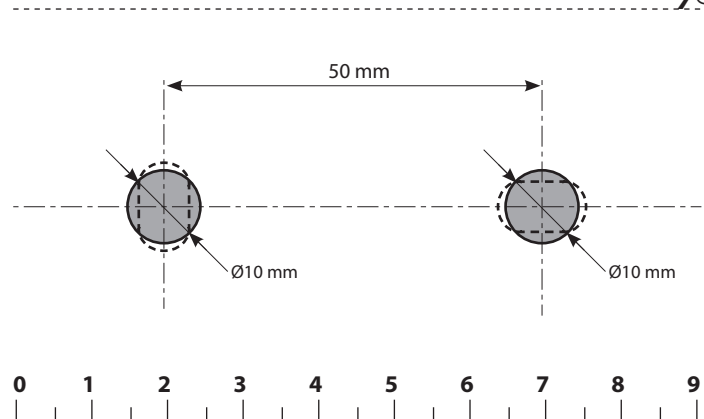

## Components

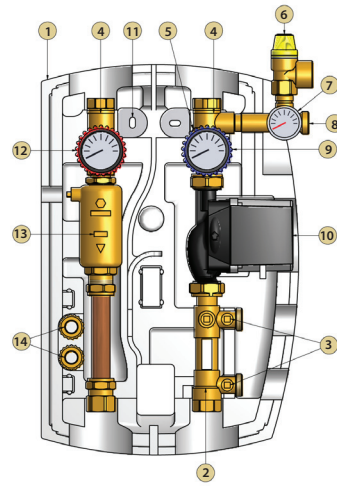

### n. Description

1	Insulation box
2	Flow rate regulator: rates 0,5÷15 l/min rates 3÷35 l/min
3	Fill & discharge valves
4	Shut-off & check valve unit
5	Blue-handle with integrated thermometer (0÷160 °C)
6	Safety valve for solar circuits (6 bar)
7	Pressure Gauge (0÷10 bar)
8	Expansion Vessel connection
9	Check valve bypass device
10	Grundfos Solar circulation pump
11	Brackets
12	Red Handle with integrated thermometer (0÷160 °C)
13	De-aerator
14	Hose connection

## Grundfos Solar 15-65 130 Pump diagram

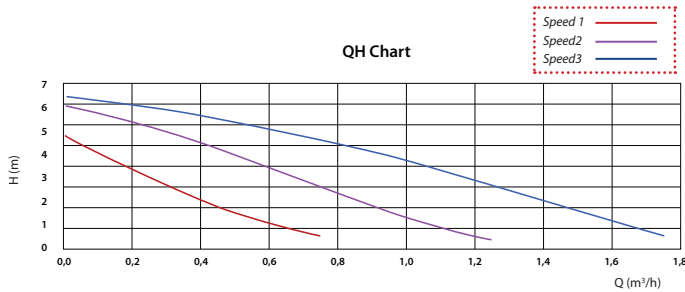

## Grundfos Solar 15-70 130 Pump diagram

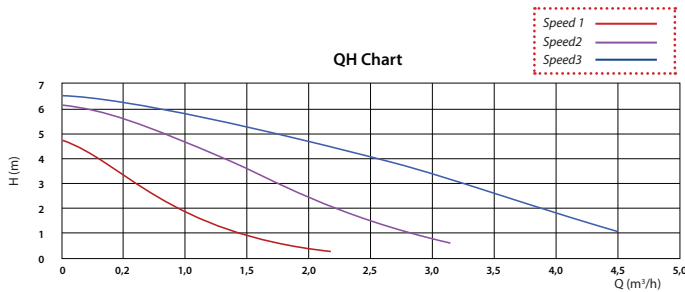

## Safety

1. The solar pump station shall be installed only by qualified personnel. Connections shall be always tight and there cannot be any hydraulic leakage during working.
2. The temperature inside the solar station can reach dangerous temperatures that can create heavy burns.

3. Pump and controller are under voltage, so disconnect the socket from the electrical network before any maintenance.
4. During the assembling, do not overload the threads, because some leakages could result during time.

*The manufacturer doesn't take charge towards injured people or damaged things because of a bad installation or of a wrong application of the articles.*

## Installation - Fixing of station

1. Remove the front shell from station.
2. Check the integrity of each component.
3. Look for a good place, suitable also for the maintenance. We suggest to leave a free space of min. 20 cm at each side of the station. Consider also the overall dimensions of the expansion vessel.

**NB: do not fix the solar station and the expansion vessel on walls unsuitable for weight heavier than 120kgs.**

4. Fix the holes' positions with the template, given as equipment. We suggest to use also a level.
5. On the wall, punch the holes with a 10 mm o.d. drill bit and insert the rawplug, with which the station is equipped to.
6. Lay the station on the wall and fix it with the screws, with which the station is equipped to (see fig. 1).
7. Connect the expansion vessel to the suitable connection.
8. Connect as illustrated in fig. 2. After having all connected, check there's no leakage in the system, testing it under pressure.
9. After having verified the system being correctly working, connect the components from the controller to the pump.

## Fill of the system

1. Before let the system work, check each connection.
2. Be sure the two shut-off valves (blue and red handles) are widely open, turning them completely anticlockwise.

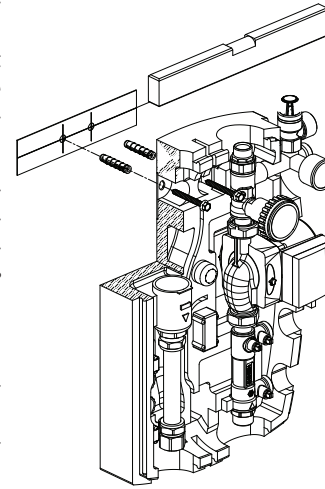

Fig. 1

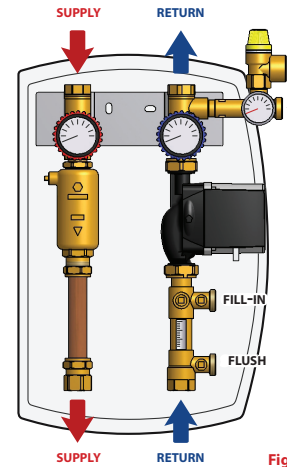

Fig. 2

3. Connect through the two fill-in/flush connections the filling device to fill the system.
4. Position the line on the shut-off valve in the horizontal position, direction fill-in/flush (see **Flowmeter** paragraph).
5. Open the fill-in/flush valves (A and B) positioning the line in the horizontal way (see **Flowmeter** paragraph).
6. From the A-valve fill-in the system until the fluid comes out from flushing-B.
7. Close B (vertical position of the line).
8. Highten the pressure 'til the required level and when reached close A-valve.
9. Switch the line of the shut-off valve in the vertical position (opened in the flow direction) to regulate the flow.
10. Switch on the pump and let it work for some minutes. Check the tightness of the system.
11. Discharge air-balls opening the air vents and discharging them from the station's de-aerator (see **De-aerator** paragraph).
12. Level again the working pressure.
13. Regulate the system's flow as required, through the flowmeter shut off valve (see **Flowmeter** paragraph) and/or regulate pump speedy.
14. After some working's hours, test again point 11 and eventually point 12.

## Maintenance/Discharging

### Cleaning:

Repeat Fill-in paragraph from point 1 to point 6. Let the fluid circulate in the system for some minutes.

### Flushing:

Flushing the system is required only if the system has been filled only with water and there's hence the risk of freezing. Connect a recycle tank to a tap on the lower part of the system.